



HFR NUT: HUP/ HMP



Definition: Self-locking nut with nylon insert.

Dimensions: HUP Nut: Standard to NF EN ISO 7040

HMP Nut: Standard to the NF EN ISO 10511.

Threading: Standard to ISO 956-2.

Characteristics and performance tests: NF EN ISO 2320/ ISO 898-2

NF EN ISO 3506-2 (Stainless Steel).

Manufacture: From diameter M3 to M24. For diameter < M3 ask for specific catalogue.

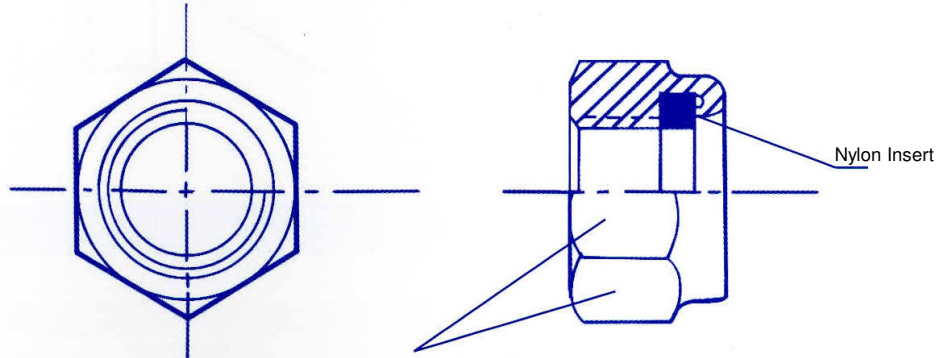

Quality Class	Classification	Range of Application
Class 8 (Grade 5)	QV	
Class 10 (Grade 8)	QK	
A2 70 (AISI 304)	ZE	-40°C +120°C (-40°F +248°F) ⁽¹⁾
A4 70	SH	
A4 80 (AISI 316L)	ZH	

⁽¹⁾ Only an indication.

Surface treatment

Galvanizing: Yellow	ZJ	} Standard to ROHS requirements
White	ZO	
White Lanthane ® Finish	ZL	
White Lanthane ® Finish + Top Coat	ZF	
Geomet ®: 600h to 1000h Salt Spray		
Antigalling: Stanal 400	ST	
(Stainless Steel) Sherardisation	SH	

Example of Ordering Code:

HUP080125ZEBT00

HUP	080125	ZE	BT	00
HUP Nut	M8 X 125	A2 70	Self Color	*

* Standard Size