



HFR NUT: EUM



Definition: All metal reusable slotted self-locking hexagon nut, with nylon insert.

Threading: Standard to the NF ISO 262 (NFE 03014) and NF ISO 965-2 (NFE 03053).

Characteristics and performance tests: NF EN ISO 2320 (NFE 25408).

NFE 25035 and NF EN ISO 3506-2.

Manufacture: From diameter M3 to M24.

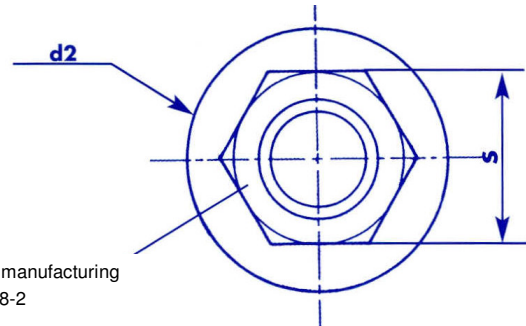
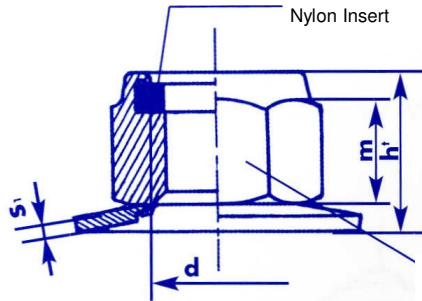

Marking of the quality class and manufacturing name following standard ISO 898-2

d	M4	M5	M6	M8	M10	M12	M14	M16
Pitch	0.70	0.80	1.00	1.25	1.50	1.75	2.00	2.00
ht	7.7	8.7	10.1	12	14.8	18.4	20.5	23.7
m	3.3	4.5	5.6	7.3	8.4	11.4	13.3	14.2
s	7	8	10	13	16	18	21	24
d2*	12	14	18	22	27	27/30**	32	40
s1	1.1	1.3	1.4	1.6	1.8	1.8	2.4	3.2

Sizes: *Only an indication. **Different type and diameter of washers can be supplied on request. **Stainless steel for diameter 27; steel for diameter 30.

Quality Class	Classification	Range of Application
Class 8 (Grade 5)	QV	Self Color -40°C +120°C (-40°F +248°F) ⁽¹⁾
Class 10 (Grade 8)	QK	
A2 70 (AISI 304)	ZE	
A4 80 (AISI 316L)	ZH	

(1) Only an indication.

Surface treatment

Galvanizing: Yellow	ZJ	} Standard to ROHS requirements
White	ZO	
White Lanthane ® Finish	ZL	
White Lanthane ® Finish + Top Coat	ZF	
Geomet ®: 600h to 1000h Salt Spray		
Antigalling: Stanal 400	ST	
(Stainless Steel) Sherardisation	SH	

Example of Ordering Code:

EUM100150ZHST00

EUM	100150	ZH	ST	00
EUM Nut	M10 x 1,50	A4 80	Antigalling	*

*Standard Size Additional Sizes, Materials and Finishes Available Upon Request

6600 Trans Canada Hwy, suite 750 Pointe-Claire, QC, H9R 4S2 Canada

T: (514)694-3250

F: (514)694-9095

e-mail: info@reduce-downtime.com

www.reduce-downtime.com