



HFR NUT: ESF



Definition: All metal self-locking riveting nut, with locking slot.

Threading: Standard to ISO 965-2.

Characteristics and performance tests: NF EN ISO 2320/ ISO 898-2
NF EN ISO 3506-2 (Stainless Steel).

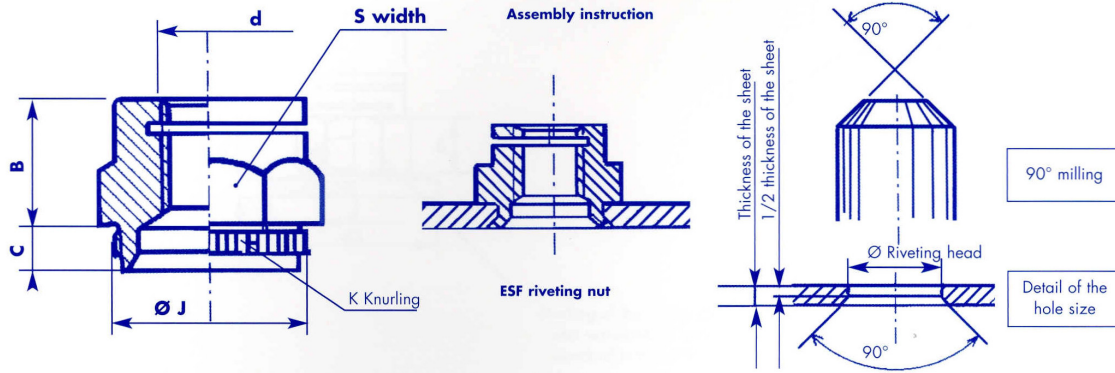

d	s	J _o + 0,05	B	C	Sheet Thickness	Ø Boring
M4	8	6,75	5,3	1,6	1,5	6,55 to 6,65
				2,2	2,0	
				2,6	2,5	
M6	11	8,9	7	2,2	2,0	8,70 to 8,80
				2,6	2,5	
				3,4	3,0	
M8	14	10,50	9,8	2,6	2,5	10,30 to 10,40
				3,4	3,0	
				4,2	4,0	

Sizes: The sheet thicknesses are examples, please contact us for other thickness.

Quality Class	Classification	Range of Application
Class 8 (Grade 5)	QV	Self color -50°C +300°C (-58°F +572°F) ⁽¹⁾
A4 80 (AISI 316L)	ZH	Corrosive atmosphere -200°C +400°C (-328°F +752°F) ⁽¹⁾

⁽¹⁾ Only an indication.

Surface treatment

Galvanizing: Yellow	ZJ	} Standard to ROHS requirements
White	ZO	
White Lanthane ® Finish	ZL	
White Lanthane ® Finish + Top Coat	ZF	
Geomet ®: 600h to 1000h Salt Spray		
Antigalling: Stanal 400	ST	
(Stainless Steel) Sherardisation	SH	

Example of Ordering Code:

ESF060100ZHST20

ESF	060100	ZH	ST	20
ESF Nut	M6 X 100	A4-80	Antigalling	*

* Sheet Thickness

6600 Trans Canada Hwy, suite 750 Pointe-Claire, QC, H9R 4S2 Canada

T: (514)694-3250 F: (514)694-9095 e-mail: info@reduce-downtime.com www.reduce-downtime.com